

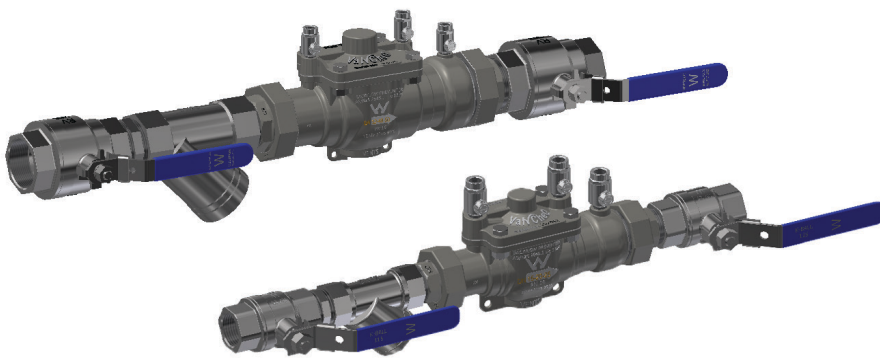

VALVCEQ BACKFLOW PREVENTERS

FIGURE RP03

Reduced pressure zone device suitable for high and medium hazard rated applications
BSP screwed connections



FEATURES

- Full stainless steel assembly for superior corrosion resistance.
- No lead product assembly.
- Lightweight compact design.
- In-line and on-site serviceable.
- No special tools required for servicing.
- Approved for hot water service up to 90°C.
- Maintenance friendly with one seal kit suitable for six valves.
- Designed and manufactured in accordance with AS/NZS 2845.1.
- Straight through flow path for maximum flow co-efficient.
- Top entry allows all parts to be accessed easily.
- Fully restrained check valve assemblies for unrivalled safety.
- Every valve is bench tested and tracked with unique serial number.
- All internal components are repairable or replaceable.
- Conforms to testing requirements of AS/NZS 2845.3.
- Lockable isolation valves included on standard assemblies.
- Anti-tamper test taps.
- Unique "ring and tail" connections conforming with Australian and International standards replacing conventional compression fittings.
- All bolting internal and external is stainless steel.
- Design conforms to all major international standards.
- Recommended for horizontal installation only.

GENERAL APPLICATION

The RP03 provides protection from both backsiphonage and backpressure of the potable water supply from contamination in high and medium hazard applications.

TECHNICAL DATA

Size range: DN 15 - 50
Temperature rating: 1°C to 90°C
Working pressure: PN16
End connections: BSPT Screwed AS 1722
Alternative threaded connections may be available on request



AS/NZS 2845.1 Lic WMKA 1324
SAI Global

VALVCEQ BACKFLOW PREVENTERS

FIGURE RP03

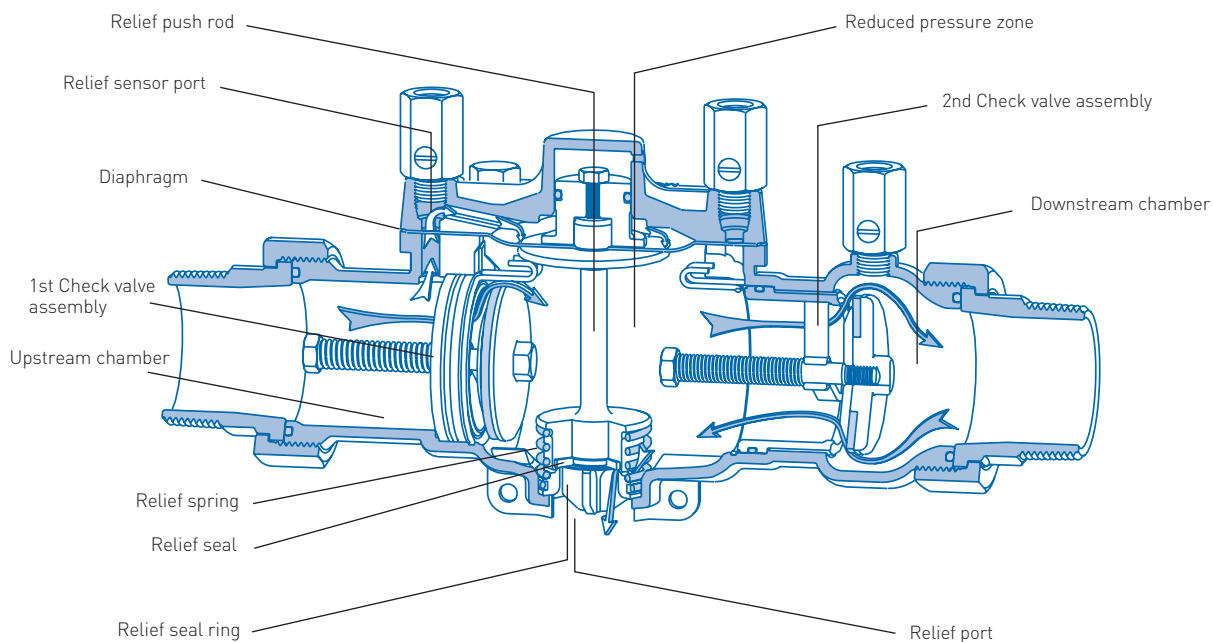

PRINCIPLE OF OPERATION

Reduced pressure zone device consists of two independently acting non-return valves in series. They are arranged to be force-loaded in the closed position. A relief valve is positioned between them and is designed to be pressure energized to vent to atmosphere when the pressure differential across the upstream non-return valve reduces to 14 kPa.

Under normal dynamic flow conditions:

Water enters the up stream chamber before the 1st check valve assembly and flows up through the relief sensor port. When sufficient water pressure is achieved (minimum of 14 kPa) above the diaphragm. It will energize the relief push rod and relief spring, moving the relief seal onto the relief seal ring closing the relief port off from atmosphere.

Once the relief port is closed, pressure builds up in the up stream chamber before the 1st check valve assembly. When this pressure is sufficient (minimum of 35 kPa) 1st check valve assembly will open allowing flow into and fill the reduced pressure zone.

The 2nd check valve assembly will open after the reduced pressure zone is full and pressurized sufficiently (minimum 7 kPa) allowing flow through the down stream chamber.

Under the condition of backpressure:

(Premises pressure is greater than supply pressure)

Water pressure in down stream chamber and spring pressure force the 2nd check valve assembly closed. If the 2nd check valve assembly is fouled by debris in the open position, the backpressure energizes the diaphragm from below and with the aid of the relief spring pulls the push rod and relief seal up off the relief seal ring opening the relief port. This allows all liquid contained in the reduced pressure zone to be relieved to atmosphere. The relief port will continue to discharge until backpressure dissipates or 2nd check valve assembly is cleared of debris.

Under the condition of backsiphonage:

(Negative/low pressure in mains supply)

The 1st check valve assembly will close under spring pressure. Water pressure in up stream chamber before the 1st check valve assembly and relief sensor port will dissipate. This will result in the relief spring opening the relief port and allowing all liquid contained in the reduced pressure zone to be relieved to atmosphere.

VALVCHEQ BACKFLOW PREVENTERS

FIGURE RP03

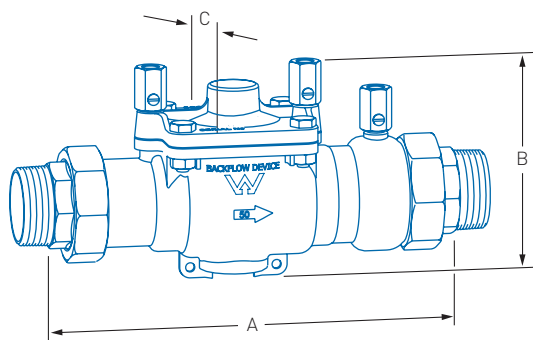

NOTE: Valve only (VO) illustrated.

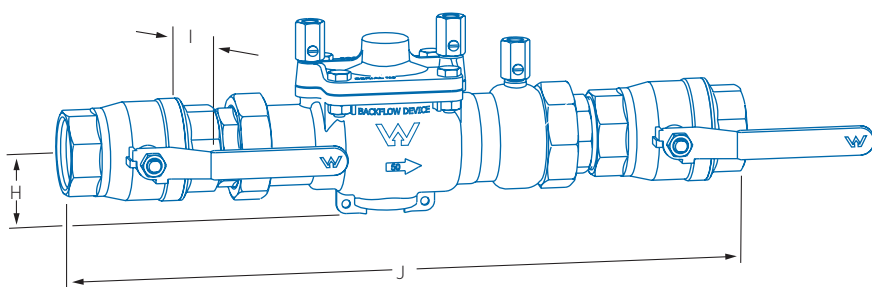

NOTE: Fire service (FS) arrangement illustrated.

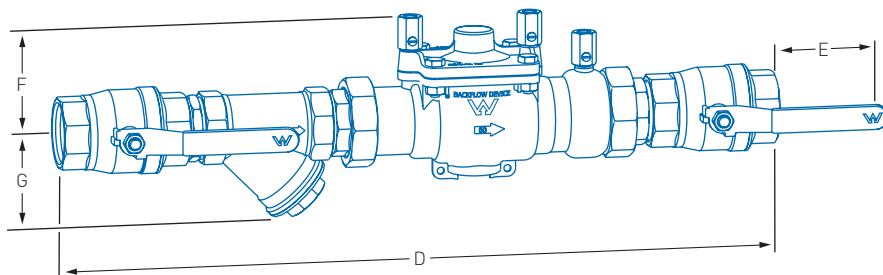

NOTE: Complete (CO) assembly illustrated.

DIMENSIONS (mm)

Valve size DN	A	B	C	D	E	F	G	H	I	J	Mass (kg)		
											VO	FS	CO
15	233	131	68	432	65	86	40	45	80	353	2.8	3.1	3.6
20	233	131	68	462	65	86	48	45	92	369	2.8	3.3	4.0
25	233	131	68	512	68	86	56	45	96	395	2.8	4.1	4.9
32	312	160	98	638	72	99	64	61	125	508	6.3	8.0	9.7
40	312	160	98	658	87	99	73	61	131	524	6.3	8.5	10.4
50	312	160	98	734	97	99	89	61	143	565	6.3	10.2	12.7

NOTE:

Dimension are nominal to ± 1 mm.

VO = Mass of valve only.

FS = Mass of fire service arrangement (no strainer).

CO = Mass of complete arrangement with ball valves.

VALVCHQ BACKFLOW PREVENTERS

FIGURE RP03

TYPICAL FLOW CHARACTERISTIC GRAPHS

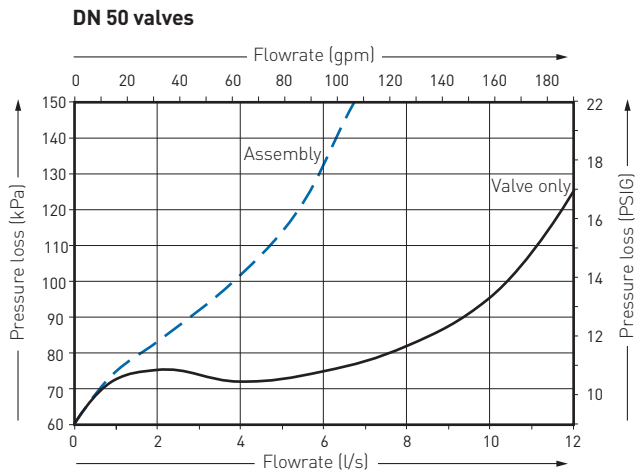
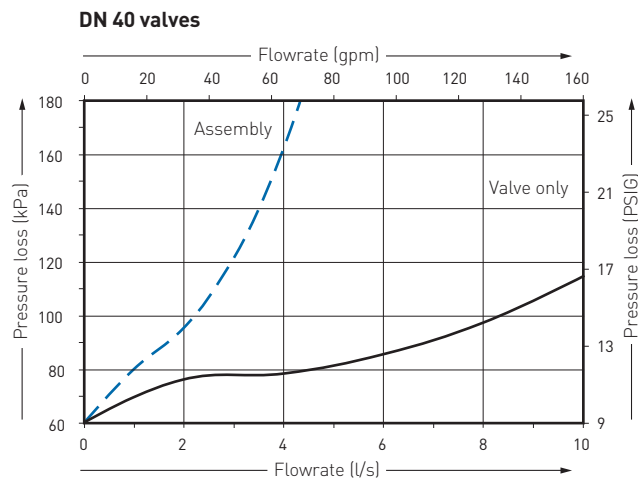
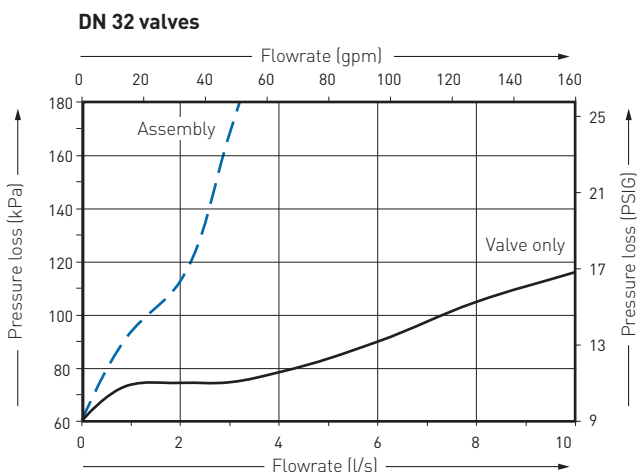
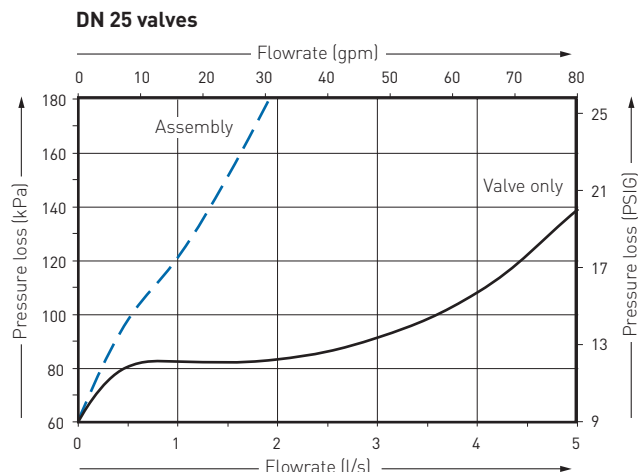
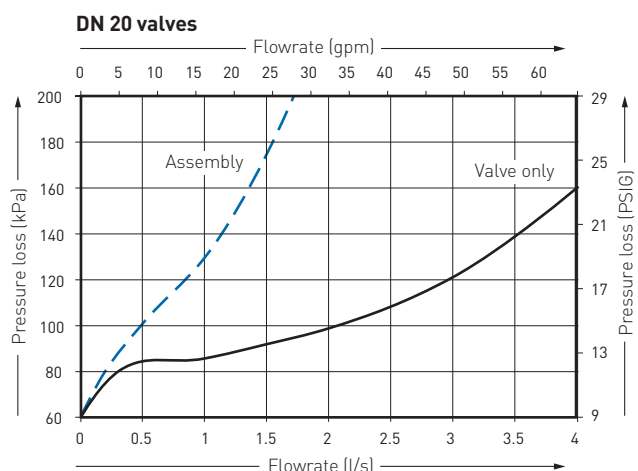
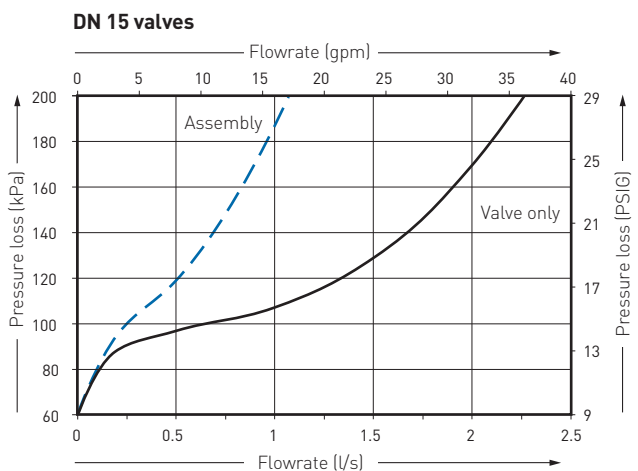

NOTE

- — Complete valve assembly
- Valve only

VALVCHEQ BACKFLOW PREVENTERS

FIGURE RP03

SELECTION GUIDE

Example:	50	RP03	BSP	CO
Valve size (DN)				
Figure no.				
End connections				
BSP	Screwed AS 1722 Alternative threads may be available on request			
Assembly				
VO	Valve only			
CO	Complete arrangement with stainless steel ball valves and strainer			
FS	Fire service (no strainer)			

NOTE:

All Emerson isolation valves come with the provision for locking.

TROUBLESHOOTING

Symptom	Cause	Remedy
First check valve not holding tight (reading approaches zero without holding)	<ol style="list-style-type: none"> 1. Debris fouling the check valve seal 2. Check valve seal damaged or perished 3. Check valve O-ring damaged 4. Check valve seal ring damaged 	<ol style="list-style-type: none"> 1. Inspect, clean, reverse or replace check seal 2. Inspect and replace check valve seal 3. Inspect and replace O-ring 4. Replace first check valve assembly
First check valve drops below 35 kPa and remains steady	<ol style="list-style-type: none"> 1. Debris fouling the check valve seal 2. Check valve seal damaged or perished 3. Check valve spring memory loss or damaged 	<ol style="list-style-type: none"> 1. Inspect, clean, reverse or replace check seal 2. Inspect and replace check valve seal 3. Replace first check valve assembly
Continuous discharge from relief port	<ol style="list-style-type: none"> 1. Debris fouling 1st check valve seal (static flow) 2. Debris fouling relief valve seal 3. Relief seal guide O-ring damaged 4. Diaphragm damaged 5. Debris fouling 2nd check valve seal (static flow) 	<ol style="list-style-type: none"> 1. Clean check valve seal 2. Clean relief valve seal 3. Replace O-ring 4. Replace diaphragm 5. Clean check valve seal
Second check valve not holding tight	<ol style="list-style-type: none"> 1. Debris fouling the check valve seal 2. Check valve seal damaged or perished 3. Check valve O-ring damaged 5. Check valve seal ring damaged 	<ol style="list-style-type: none"> 1. Inspect, clean, reverse or replace check seal 2. Inspect and replace check valve seal 3. Inspect and replace O-ring 5. Replace second check valve assembly
Relief port not opening before 14 kPa	<ol style="list-style-type: none"> 1. Diaphragm damaged 2. Relief spring memory loss 	<ol style="list-style-type: none"> 1. Replace diaphragm 2. Replace spring
Discharge from inspection port in top cover	<ol style="list-style-type: none"> 1. Debris fouling relief valve guide O-ring 2. Damaged relief valve guide O-ring 	<ol style="list-style-type: none"> 1. Inspect and clean O-ring 2. Replace O-ring

VALVCEQ BACKFLOW PREVENTERS

FIGURE RP03

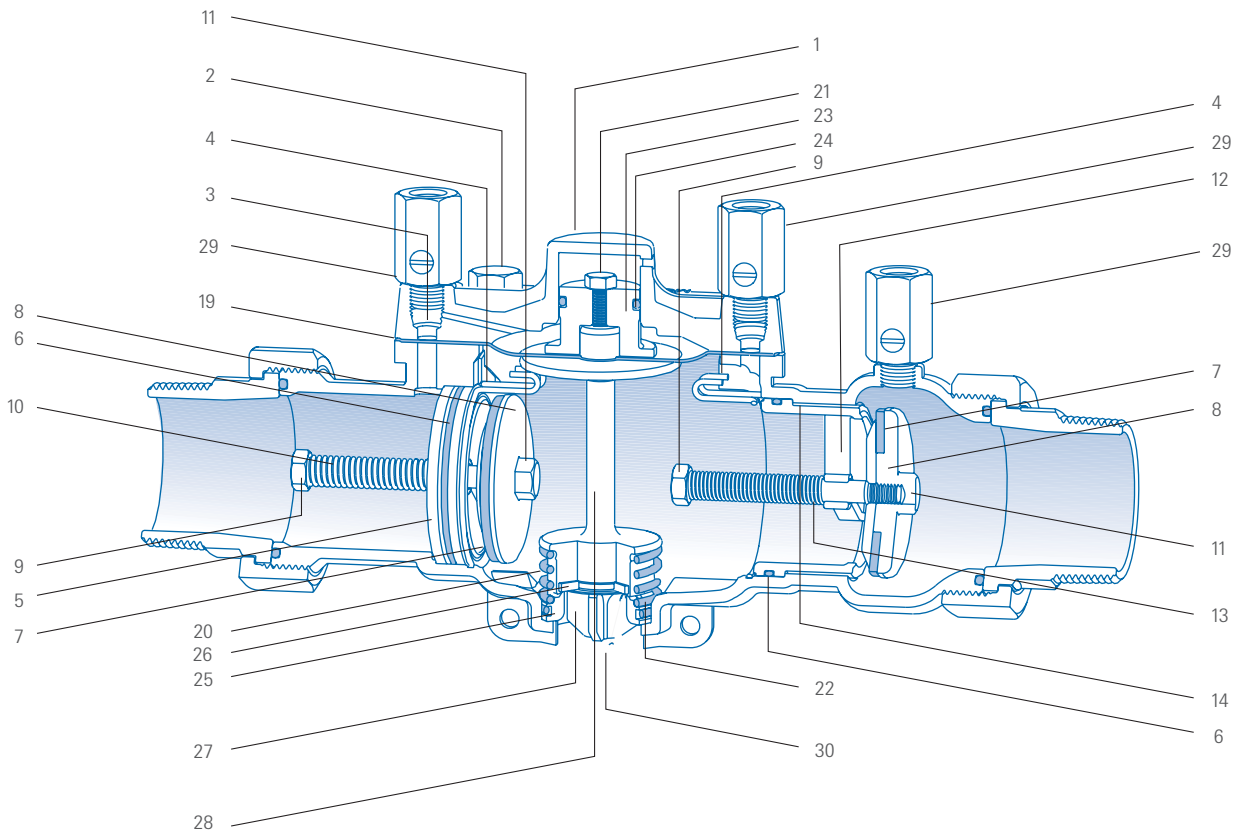

PARTS LIST

No.	Description	No.	Description
1	Cover plate	14	Second check valve extended body seal ring
2	Cover plate bolts	19	Relief valve diaphragm
3	Relief sensor port	20	Relief valve spring
4	Check valve circlip	21	Relief valve top guide bolt
5	1st check valve seal ring	22	Relief valve seal guide O-ring
6	Check valve O-ring	23	Relief valve guide
7	Check valve seal	24	Relief valve guide O-ring
8	Check valve disc	25	Relief valve seal ring
9	Check valve stem	26	Relief valve seal
10	First check valve spring	27	Relief valve seal retainer
11	Check valve retaining nut	28	Relief valve push rod
12	Second check valve seal ring	29	Test taps
13	Second check valve spring	30	Relief port

VALVCEO BACKFLOW PREVENTERS

FIGURE RP03

Complete safety and maintenance instructions for high hazard devices

MAINTENANCE AND TESTING REQUIREMENTS

Test after initial installation and annually for the life of the valve or service. Maintain in a working order and inspect for operational function at intervals not exceeding twelve months. The functions are to be carried out by authorized licensed backflow testers.

DISASSEMBLY INSTRUCTIONS

Main valve

1. As per safety precautions slowly close isolation valves and the open test taps (29) to drain relief port.
2. Remove cover plate bolts (2).
3. Remove cover plate (1), relief assembly consisting of relief valve top guide bolt (21), relief valve guide (23), relief valve diaphragm (19), relief valve push rod (28), relief valve seal (26), relief valve seal retainer (27) and relief valve spring (20) may pull out as one piece connected to top cover.
4. Separate cover plate (1) from relief assembly.

Relief assembly

1. To access relief valve diaphragm (19), remove relief valve top guide bolt (21) from relief valve guide (23), by screwing a coverplate bolt (2) for 15 mm - 25 mm or M8 x 30 bolt for 32 mm - 50 mm into thread provided on top of relief valve guide (23) to separate guide (23) from relief valve push rod (28).
2. To access relief valve seal (26), separate relief valve spring (20) from relief valve push rod (28).
3. Turn relief valve seal retainer (27) anti-clock wise and remove from relief valve push rod (28).
4. To access relief valve seal guide O-ring (22), push relief valve seal ring (25) through from underneath relief port.

Check valve assemblies

1. Utilizing both sets of circlip prongs, squeeze together and pull out 1st and 2nd check valve assembly circlips (4).
2. To remove 2nd check valve assembly pull check valve stem (9) out then up, bringing the check assembly through the top entry of the valve.
3. To remove 1st check valve assembly, block relief sensor port (3) and slowly crack open inlet isolating valve allowing the water pressure to push the check valve assembly into the intermediate chamber. Shut off inlet isolating valve and remove check assembly through the top entry of the valve.
4. Both check valve assemblies are mechanically the same, so the same procedure can be used for both assemblies. Fit spanners to the check valve stem head (9) and to the check valve retaining nut (11) then turn check disc anti-clockwise and remove.
5. Remove check valve disc (8) to exposes check valve seal (7) for servicing or replacement.

NOTE:

When reassembling:

- Lubricate all O-rings.
- 2nd check valve assembly has the extended body.
- Check valve seal (7) and diaphragm (19) must be clean, free of any greases, moisture and debris upon assembly.

SAFETY PRECAUTIONS

In every instance of installation or removal from the pipeline, ensure the line is not pressurized and any hazardous liquid is drained away. Slowly close both isolating valves and then open test taps (29) to drain relief port.

VALVCHEQ BACKFLOW PREVENTERS

FIGURE RP03

Specifications for reduce pressure zone device suitable for high and medium hazard rated applications

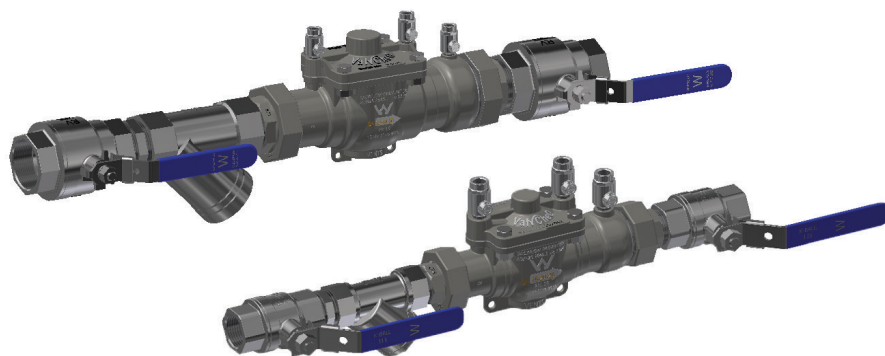

- Valve shall be manufactured and approved to AS/NZS 2845.1.
- The assembly shall be connected with the "ring and tail" to allow easy removal or replacement of the device in accordance with AS/NZS 3500.
- Complete assembly including main valve and internals shall be of stainless steel construction and to have pressure rating of PN16 and a temperature rating of 90°C.
- All internal parts and elastomers are to be accessible through a top entry point of the main valve to allow inline maintenance.
- Valve shall also be fitted with test points with BSPT threads to allow testing to AS/NZS 2845.3.
- The assembly is fitted with locking mechanism to provide adequate security as standard.

VCTDS-02933-EN © 2015, 2021 Emerson Electric Co. All rights reserved 02/21. ValvCheQ is a mark owned by one of the companies in the Emerson Automation Solutions business unit of Emerson Electric Co. The Emerson logo is a trademark and service mark of Emerson Electric Co. All other marks are the property of their prospective owners.

The contents of this publication are presented for informational purposes only, and while every effort has been made to ensure their accuracy, they are not to be construed as warranties or guarantees, express or implied, regarding the products or services described herein or their use or applicability. All sales are governed by our terms and conditions, which are available upon request. We reserve the right to modify or improve the designs or specifications of such products at any time without notice.

Emerson Electric Co. does not assume responsibility for the selection, use or maintenance of any product. Responsibility for proper selection, use and maintenance of any Emerson Electric Co. product remains solely with the purchaser.

Emerson.com/FinalControl